

KIRKHAM

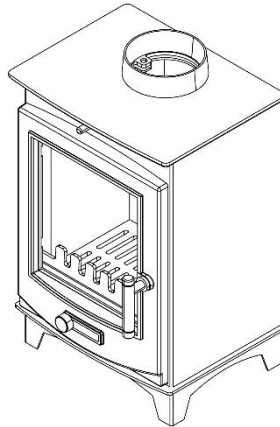

INSTALLATION MANUAL AND USER OPERATING INSTRUCTIONS

THIS STOVE MUST ONLY BE INSTALLED BY A SUITABLY QUALIFIED AND COMPETENT PERSON REGISTERED WITH THE APPROPRIATE COMPETENT PERSONS SCHEME.

Please leave this booklet with the stove user and instruct them on the correct use of the stove, operation of the controls and the correct fuel types to burn focusing on both efficiency and environmental considerations.

Stoves operate at very high temperatures.

All persons including children must be warned of this and should be discouraged from touching any surfaces whilst the stove is in use. This includes the connecting flue pipe, glass, controls and door handle. When refuelling the operator must use the glove provided and limit the time the door is left open when doing so.

CONTENTS

1.0 STOVE INFORMATION

- 1.1 Declaration of Performance and Technical Data Page 03
- 1.2 Stove Dimensions Page 04
- 1.3 Component Spare Parts Page 05

2.0 INSTALLATION AND OPERATION

- 2.1 Safety Information Page 06
- 2.2 Installation Page 07
- 2.3 Specific Installation Information Page 11
- 2.4 Operation Page 13

3.0 MAINTENANCE

- 3.1 General Maintenance Page 18
- 3.2 Seasonal Maintenance Page 20

4.0 SAFETY NOTES AND TROUBLESHOOTING

- 4.1 CO Alarms Page 20
- 4.2 Over-firing Page 20
- 4.3 Smoke/POC Entering the Room Page 21
- 4.4 Chimney Fire Page 21
- 4.5 Poor Heat Output Page 22
- 4.6 Room Ventilation Restricted Page 22
- 4.7 Fuel Quality Page 22
- 4.8 Dirty Glass Page 22
- 4.9 Un-burnt Fuel Page 22

5.0 STOVE ACCESSORIES

Page 24

1.0 STOVE INFORMATION

1.1 DECLARATION OF PERFORMANCE & TECHNICAL DATA

Kirkham	
Intended area of use:	Domestic heating appliance
Standard:	BS EN 13240: 2001 + Amd 2: 2004
Test institute:	Kiwa Gastec
Appliance weight:	56kg
Flue outlet:	125mm
Essential characteristics burning WOOD (at nominal 12Pa flue draught)	
Efficiency: (%)	82.5
Nominal output: (kW)	5.0
Refuel interval: (h)	0.81
Mean flue gas temperature: (°C)	254
Flue gas mass flow: (g/s)	3.8
Mean CO emission @ 13% O ₂ : (Nmg/m ³)	0.05
Mean C _n H _m emission @ 13% O ₂ : (Nmg/m ³)	44
Mean NO _x emission @ 13% O ₂ : (Nmg/m ³)	73
Mean Particulates @ 13% O ₂ : (Nmg/m ³)	26
Essential characteristics burning MAXIBRITE (at nominal 12Pa flue draught)	
Efficiency: (%)	80.8
Nominal output: (kW)	5.0
Refuel interval: (h)	1.03
Mean flue gas temperature: (°C)	287
Flue gas mass flow: (g/s)	3.5
Mean CO emission @ 13% O ₂ : (Nmg/m ³)	0.06
Mean C _n H _m emission @ 13% O ₂ : (Nmg/m ³)	23
Mean NO _x emission @ 13% O ₂ : (Nmg/m ³)	82
Mean Particulates @ 13% O ₂ : (Nmg/m ³)	20
Distances to combustible materials	
Rear wall: (mm)	500
Side wall: (mm)	600
Directly above stove: (mm)	600

1.2 STOVE DIMENSIONS

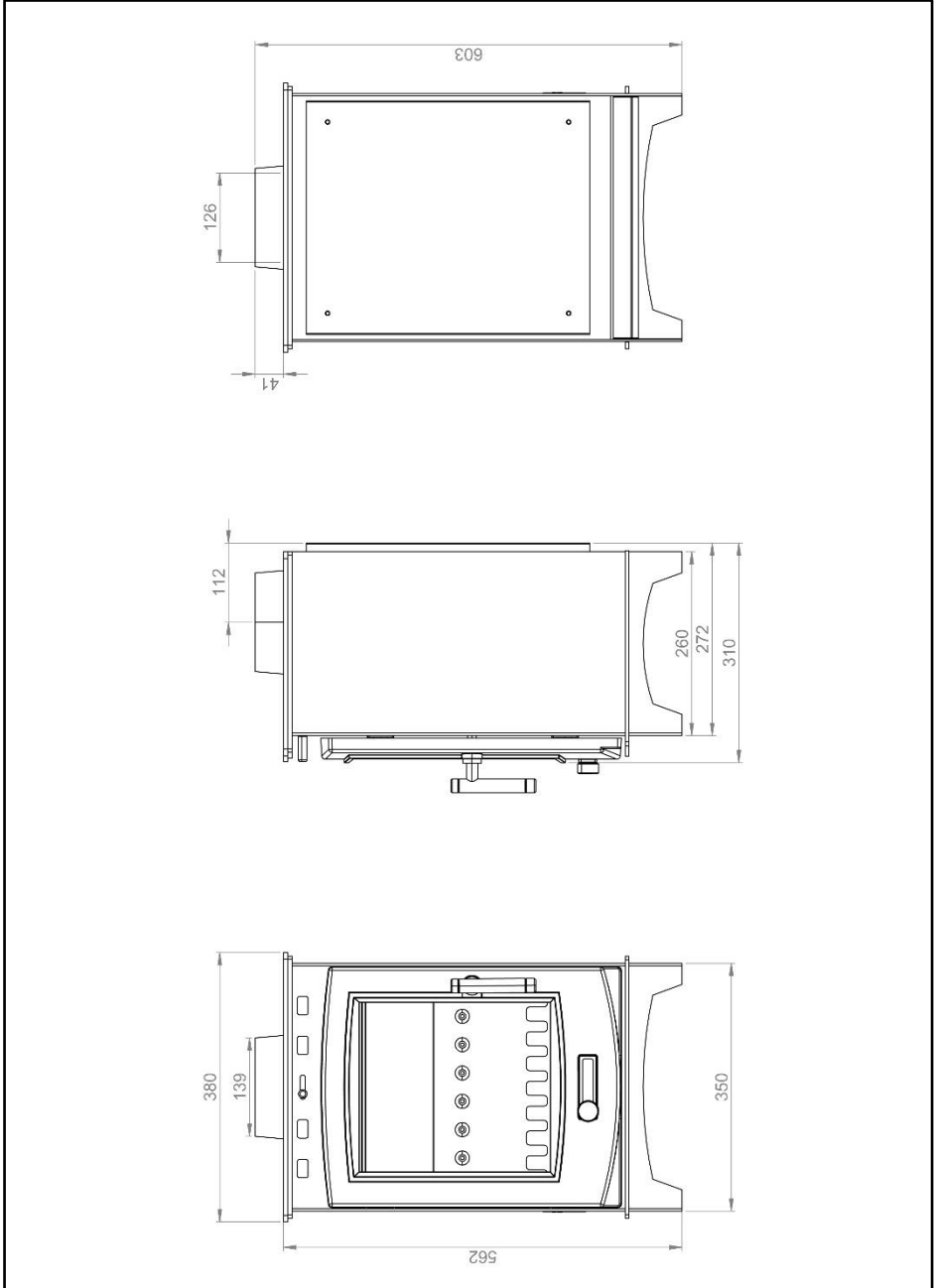

1.3 COMPONENT SPARE PARTS

Please see below the list of spares available for your stove. Only the approved manufactures spare parts must be used. Any attempt to fabricate a replacement or to modify any parts of the stove will invalidate the warranty and may render the stove dangerous. This could also have a detrimental effect on the environment.

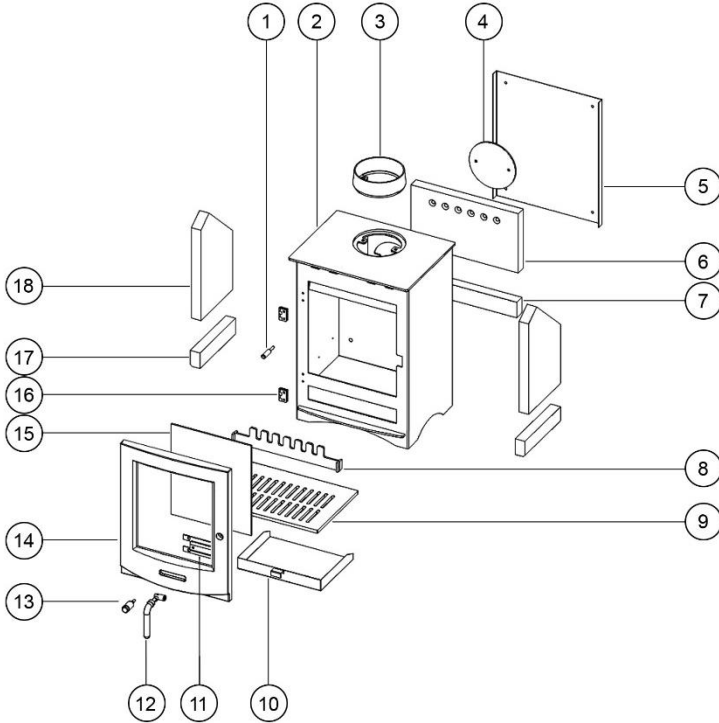

ITEM	DESCRIPTION	ITEM	DESCRIPTION
1	Secondary control knob	11	Primary control slider
2	Stove body	12	Door handle
3	Flue collar	13	Primary control knob
4	Flue blanking plate	14	Door
5	Rear heat shield	15	Ceramic glass panel
6	Rear chamber brick	16	Door hinge x 2
7	Rear grate support brick	17	Side grate support brick x 2
8	Fuel retaining bar	18	Side chamber brick x 2
9	Grate	19	Baffle plate (not shown)
10	Ash pan	20	Hearth insulation brick x 2 (not shown)

2.0 INSTALLATION AND OPERATION

2.1 SAFETY INFORMATION

IMPORTANT: This stove must only be installed by a registered, suitably qualified and competent person in accordance with BS8303 and the current national building regulations, understanding that such regulations may differ throughout the UK.

HANDLING – When lifting the stove the installer must comply with the Manual Handling Operations Regulations 1992, as amended by the Health and Safety Regulations 2002. In doing so carrying out risk assessment to control and reduce the risk of injury from lifting the stove.

FIRE CEMENT – Some types are caustic and should not be allowed to come into contact with the skin. Always refer to the relevant COSHH information and use any recommended protective equipment such as gloves. In case of contact with skin wash immediately with plenty of water and seek medical advice if necessary.

ASBESTOS – These stoves contain no asbestos. During the installation, should you suspect any asbestos within the building fabric you must follow the Control of Asbestos Regulations 2012 Approved Code of Practice and Guidance.

METAL PARTS – When installing or servicing this stove care should be taken to avoid the possibility of personal injury. The installation and servicing must be in accordance with the Health and Safety at Work Act and the manufacturer of the stove accepts no liability if this advice is not followed. In all instances a risk assessment must be completed when installing and working on the stove. This stove has been extensively tested for safety and efficiency and it must not be modified in any way. Any attempts to do so may compromise the safety and may become to the detriment of the environment. Always use approved manufacturers replacement parts as recommended by your supplier. Failure to adhere to this advice will invalidate your warranty.

SPILLAGE TESTING – Where an extractor fan is fitted within the same room, the stove must be tested for its safe operation under the worst case condition with the extractor fan running at maximum speed. If the stove does not operate safely then it must be disconnected until such time provisions have been made to either disconnect the extractor fan or complete a satisfactory spillage test. Guidance on spillage testing must sought and completed in accordance with BS8303.

We do not recommend that an extractor fan is fitted into the same room as the stove after it has been installed as it may be detrimental to the performance of the stove resulting in spillage of products of combustion.

With every installation a carbon monoxide detector/ (co) alarm must be installed in the same room as this stove. See below for advice on positioning.

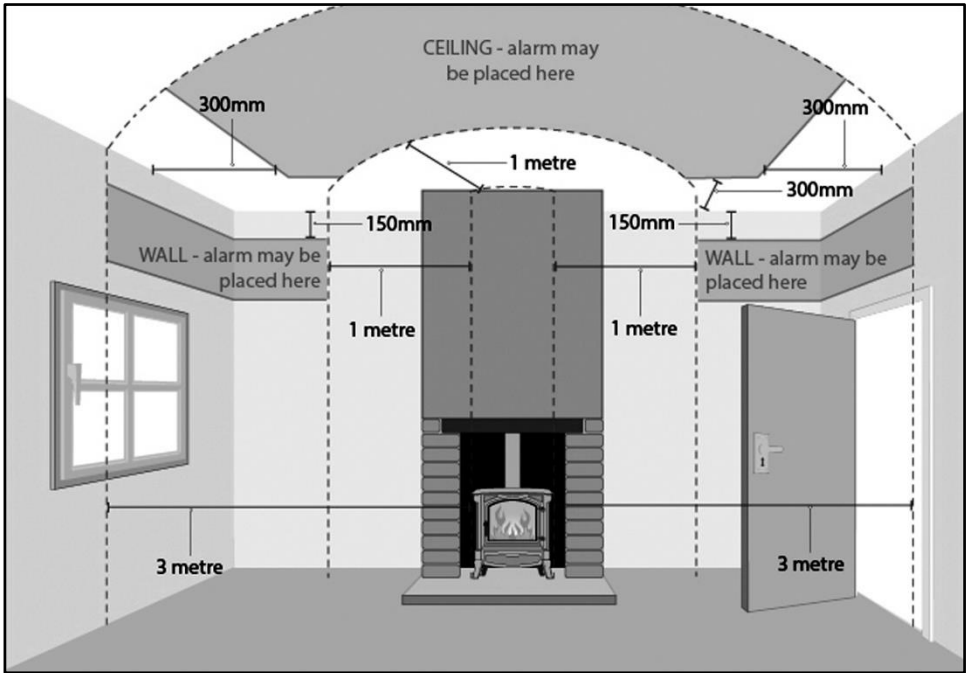

2.2 INSTALLATION

Ensure all parts are fitted in accordance with the stove installation manual. To make it easier to handle the stove on installation it may help to remove the baffle plates, bricks and door. Place these in a secure place to avoid damage and refit after installation.

On completion of the installation and commissioning ensure that the operating instructions for the stove are left with the end user. The installer must advise the end user on the correct use and operation of the stove and advice and guidance must be given in relation to the correct usage of fuel types as recommended in this document. The installer must also advise the end user on how to light the stove for best results and how to maintain an optimum burn cycle, in doing so also minimizing the time that the stove door is open during refuelling.

This stove must not share a chimney with any other appliance - this includes gas appliances as well as solid fuel.

Where a masonry chimney is believed to have previously served an open fire installation, it is possible that the higher flue gas temperature from a closed appliance may loosen deposits that were previously firmly adhered, with the consequential risk of a flue blockage. It is therefore recommended that a masonry chimney should be swept a second time within a month of regular use after installation. It is important to clean the stove flue-ways, flue-pipe and chimney prior to operating after a prolonged shut-down period, keeping the stove well ventilated during long periods of not using is also important to prevent a build-up of condensation and rust forming.

Check the chimney is in good condition, dry, free of cracks, obstructions and integral throughout. The cross sectional diameter of the brick chimney should not be less than 125mm and not more than 230mm. If any of these requirements are not met, the chimney should be lined by a suitable method using a liner with a cross sectional diameter not less than 125mm.

On completion of the installation allow a suitable period of time for any fire cement and mortar to dry out, before lighting the stove. Once the stove is under fire check all seals for soundness and check that the flue system is functioning correctly and that all products of combustion are being removed safely and vented to atmosphere via the chimney termination point, which must only be an approved terminal.

When installing this stove, a 125mm flue liner may be used in accordance with BS8303 and current Building Regulations. The chimney and connecting flue pipe should not be less than the size of the outlet socket (collar) of the stove at any point.

The chimney height and the position of the chimney terminal must be in accordance with the current Building Regulations and conform to the latest edition of BS EN 15287-1:2007, Design, Installation and Commissioning of Chimneys.

On commissioning the Stove, a flue draught reading must be taken and documented on the commissioning certificate this reading ensures the stove is operating within its designed parameters and its optimum efficiency. A sample point has been included on this appliance and is located on the top right-hand side of the stove.

Light the appliance following the procedure on Page 14. Allow the appliance and chimney to reach their normal operating conditions. **Care should be taken when proceeding with the test as all stove parts will now be hot.**

Remove the screw from the test point and insert the hose or test probe of the manometer or draught gauge. Record the reading in pascals (Pa). The optimum reading should be in the range of 12-15Pa. A flue draught may exceed 15Pa but must not exceed 24Pa. Anything above 24Pa may result in the over-firing of the stove. As a direct consequence of this the fuel consumption will be excessive which may result in a chimney fire. Remove the hose or test probe and replace the screw confirming the test point is sealed.

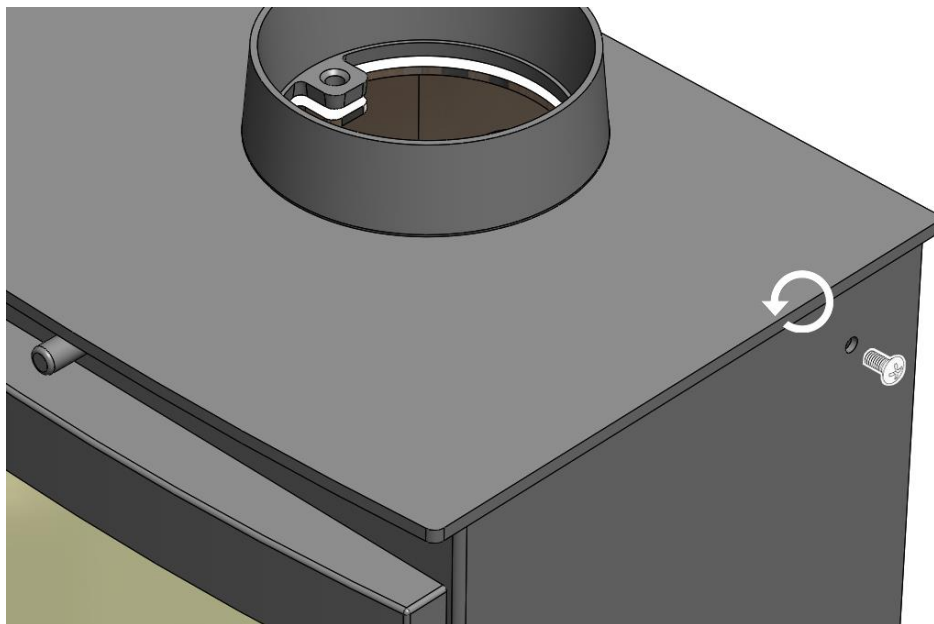

If the flue draught is outside the specified range for the appliance, remedial action is necessary to correct the problem and allow the chimney to operate at the correct draught. This might typically include adding a draught stabilizer to reduce too high a draught or lining and insulating an overly large chimney if the draught is too low. The chimney must be swept before fitting a liner to the stove and it is a condition of the warranty that it must be swept every twelve months thereafter, but not limited to depending on use. If used regularly, it is recommended that your chimney is swept every six months.

An existing fireplace opening can be modified to accommodate the stove. The following pages identify some typical installation scenarios and provides the necessary specific installation information for your new stove. Always consult your installer for a detailed survey.

Typical Installation for Inglenook Fireplaces – Top Flue

Inglenook fireplaces can have very large bore chimneys. Check with your installer – you are likely to require a stainless steel flexible liner for solid fuel if your chimney is larger than 230mm x 230mm. A closure plate with access for cleaning may also be required together with a short length of flue pipe of the same diameter as the stove flue collar.

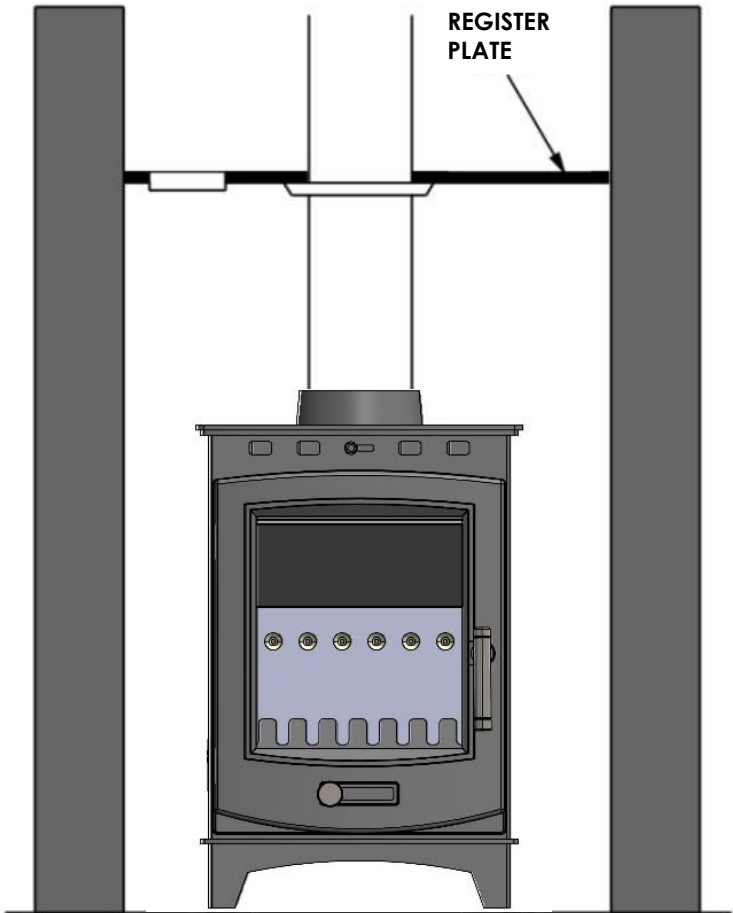

Typical Installation for Inglenook Fireplaces – Rear Flue – Side View

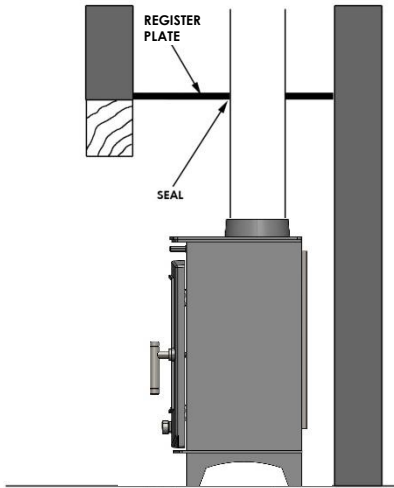

Typical Installation Into In-filled Masonry Fireplaces

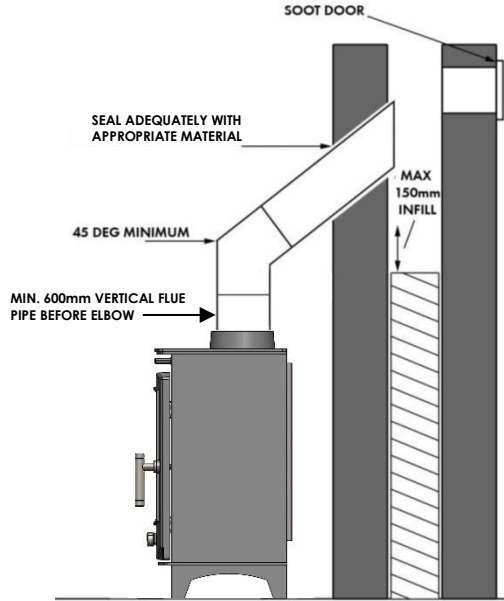

2.3 SPECIFIC INSTALLATION INFORMATION

2.3.1 Clearances

Distances to combustible materials:

REAR (mm)	SIDES (mm)	TOP (mm)
500	600	600

Distances to combustible materials above the stove:

As there are many possible configurations of potential fireplace furnishings above the stove (e.g. timber fireplaces, beams, etc.), each with their own physical properties, it is not possible to provide absolute guidance on exact distances. Materials above the stove are far more likely to overheat than those beside or underneath. As a guide, the limiting temperature for SOLID timber is +60°C above ambient room temperature. Please refer to all associated product and building regulations for further guidance.

Distances to NON-combustible materials:

The stove can be recessed into a suitably sized fireplace built from non-combustible materials, but a permanent free air gap of at least 100mm should be left around the sides and top to obtain maximum heat output and for access to the rear of the stove.

Any encroachment on this will require an adequate risk assessment of this installation and sufficient provisions made for future service and maintenance.

It is possible to fit the stove with less clearance around it – down to 50mm, but the non-combustible material around it must be at least 150mm thick. This is normally achieved when installing into a standard brick-built chimney breast with double thickness walls to the rear and sides of the builder's opening. Take care that the wall finish is suitable to withstand temperatures of up to 400°C.

2.3.2 Hearths

Allow a hearth apron of at least 225mm at the front of the stove, 150mm on either side and be a minimum thickness of 50mm. Care should be taken to secure the hearth and ensure it is level when the stove is in its final resting position. If existing floors do not have adequate load bearing capacity then a risk assessment must be completed taking into account the loading of the installation whole.

2.3.3 Ventilation

If the room in which the stove is fitted has an air permeability of more than $5.0\text{m}^3/(\text{h}\cdot\text{m}^2)$ (typical of house built pre 2008) then on a satisfactory commission of the appliance no additional ventilation is necessary.

Flues With No Flue Draft Stabiliser

When the room permeability is less than $5.0\text{m}^3/(\text{h}\cdot\text{m}^2)$ (typical of house or extension built after 2008) and there is no flue stabiliser fitted this stove will require at least 2700mm^2 of permanent ventilation.

Flues With a Flue Draft Stabiliser

When the room permeability is less than $5.0\text{m}^3/(\text{h}\cdot\text{m}^2)$ (typical of house or extension built after 2008) and there is a flue draught stabiliser fitted then this stove would need a minimum of 4250mm^2 of permanent ventilation.

2.3.4 Top or Rear Flue

Remove the collar and accessory pack from the stove. The stove will arrive with the blanking plate fitted to the rear. This can be removed if required allowing the collar to be fitted for rear flue installations. The blanking plate when removed from the rear flue must then be reinstalled to the top outlet.

2.4 OPERATION

Always open the stove door slowly to refuel and limit the time the door is open. During the operation the stove handle may become hot so always wear the glove provided.

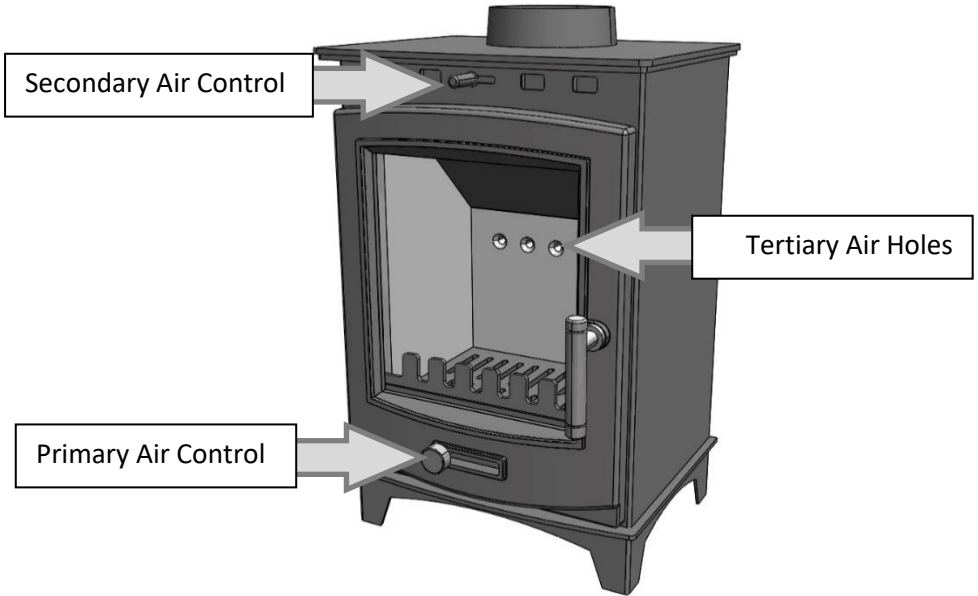

2.4.1 Primary Air - controllable

Primary air is controlled via the sliding vent in the bottom of the door. This provides an air draught through the grate to the bed of the fire. Slide right to open and left to close. Open this when you start a fire, and to regulate solid fuels other than wood. It should be closed when a wood fire is established for the best efficiency but can be used to give a wood fire a boost when it is dying out.

2.4.2 Secondary Air - controllable

Secondary air is controlled via the sliding vent above the door, it is this 'airwash' that keeps a clean and uninterrupted view of the fire, and also aids good secondary combustion of fuel; thus reducing emissions in the chimney and out to the environment. Slide to the right to open and to the left to close. Use this to control wood fires. It should be closed when burning solid fuels other than wood for the best efficiency after the fire is established.

2.4.3 Tertiary Air – not controlled (fixed supply)

The Tertiary Air Supply is bled into the stove from the rear panel. Its function is to ignite unburned gasses helping provide a clean burn. It is advisable to clear these holes from time to time with a brush, especially when the stove is being serviced or after long periods of burning. **Only carry out this and all servicing procedures when the stove is cold.** This tertiary air supply is permanently open and allows a small amount of air into the stove. Operation with air controls open can cause excess smoke. These stoves must not be operated with air controls left open except as directed in these instructions.

2.4.4 Lighting the Stove

It is essential that you have three or four small fires before you operate the stove to its maximum heat output. This is to allow the paint to cure and to “temper” your cast iron stove. We recommend this ‘running-in’ procedure after long shutdowns to preserve the life of stove. During the curing of the paint you may notice an unpleasant smell. It is not toxic, but for your comfort we would suggest that during this period you leave doors and windows open.

First, load the fire with starting fuel i.e. dry kindling timber and/or firelighters with either fuel chosen, wood or smokeless coal. It is normal to see smoke coming from the open stove door at this stage.

Light the fire at the base leaving all air controls open. Allow the fuel to reach a steady glow and build up the fire gradually. It may be helpful to leave the door ajar (10mm-15mm) for 2-3 minutes to help establish the fire. Once you have a good fire established across the fuel bed, further fuel can be added as required. It is important not to overload at any point.

When your fire is well established you can start to restrict the primary air intake. If you are burning only wood, the primary air control can be fully closed. If you are burning solid fuel you will require some primary air. Your stove is burning with maximum efficiency when a bright fire is achieved using minimum air inlet and a Stove Thermometer. We advise that stove thermometer is purchased in order to for you to monitor the operation of the stove. For best results the thermometer should register within the “Best Burn” range.

2.4.5 Wood Burning

Wood burns best on a bed of ash and it is therefore only necessary to remove surplus ash from the grate occasionally. Burn only kiln dried or well-seasoned wood, which should have been cut, split and stacked under cover for at least 36 months, with free air

movement around the sides of the stack to enable it to dry out. Burning wet or unseasoned wood will create tar deposits in the stove and chimney and will reduce heat output. Tar deposits, if allowed to build up, are a major cause of chimney fires. This tar also is the main cause of blackened stove windows. A wood moisture meter is a handy device to have. **Caution** – only empty the ash pan when the stove is cool.

Once established and for the best results from your stove, load only 1.2kg of good quality dry wood per hour with the primary air control fully closed and the secondary air control approximately 5mm open. We recommend using 2 logs at approximately 160mm. Longer logs may be used up to a length of 230mm. Do not overload as this can potentially cause damage to the stove and chimney system.

Of course, best burning depends on the quality of wood, draft and stove settings, so please do experiment to find your own best settings and the best position on your Stove Thermometer but guidance should be sought initially from your installer when the commissioning takes place.

2.4.6 Other Solid Fuel Burning

Always clean out the ash pan before refuelling and do not let the ash build up to the underside of the grate bars – this will severely reduce the life of the grate and prevent efficient burning. Solid fuel produces ash, which if allowed to build up, will stifle the air flow through the grate and eventually cause the fire to die. **Caution** – only empty the ash pan when the stove is cool.

With some solid fuels a residue of burnt fuel or clinker will accumulate on the grate, allow the fire to go out periodically to remove this.

Once established and for the best results, load only 0.5 kg of anthracite or equivalent per hour with the primary air control about 50-75% open and the secondary air control fully closed. Do not overload as this can potentially cause damage to the stove and chimney system.

When loading fuel, ensure that the series of tertiary air holes on the rear chamber brick are not covered by the fuel.

Of course best burning depends on the type of fuel being burnt, draft and stove settings, so please do experiment to find your own best settings but guidance should be sought initially from your installer when the commissioning takes place.

2.4.7 De-ashing

During stove use, whilst burning anthracite or a mix of wood and anthracite, from time to time the fire must be agitated with a poker to remove ash ensuring

airflow through the fire bed and allowing the fire to burn over the whole grate. Ensure you use the glove provided.

2.4.8 Recommended Fuels

Please note that HETAS Ltd Appliance Approval only covers the use of wood logs and approved smokeless fuels on this appliance. HETAS Ltd. Approval does not cover the use of other fuels either alone or mixed with the recommended fuels listed above, nor does it cover instructions for the use of other fuels.

Only the fuels specified for use in this manual are recommended. Any unauthorised fuel use will void the stove warranty.

Wood - Only kiln-dried or well-seasoned wood with a moisture content reading of less than 18% is recommended. A moisture meter is a useful device to measure the moisture content of wood. Generally, wood seasons at about 1" (25mm) per year, so a log split such that along its length no dimension is greater than 3" (75mm), it would take about 3 years to dry. A dry log will produce up to four and a half times more heat output than a freshly cut log. Wet logs take heat to dry and if burned in this state will cause incomplete combustion and will be detrimental to the performance of the appliance, and the environment.

Other Solid Fuel – “Authorised” fuels include anthracite large nuts, briquettes smokeless fuel, ie. Ancit, Phurnacite, Taybrite, Homefire Ovals suitable for closed appliances. Bituminous coals can cause tar deposits and burn very hot, it is also recommended that the sulphur content is checked when burning this type of fuel.

2.4.9 Unauthorised Fuels

Do not burn Wildfire, Housecoal, household coal, petroleum cokes or household waste. If in doubt consult your supplier or the Solid Fuel Association.

Please note that when refuelling with solid fuel, do not pile fuel higher than 30 degrees from the front bar rearwards – over-fuelling can cause excess smoke and produce temperatures beyond the designed rating of the stove causing damage to internal parts and chimney system.

This stove is designed to be operated with the door closed, except for when lighting for the first time when initially trying to establish the fire. When refuelling always minimize

the length of time that the door is open to avoid hindering the air quality within the room. Not only is it unsafe to operate with the door open but the stove efficiency will be significantly reduced and excess smoke can become distributed.

The Kirkham is designed to operate intermittently and must not be used as an overnight burner (often termed as slumbering).

Clean Burn - The Clean Air Act 1993 and Smoke Control Areas

Local authorities may declare the whole or part of their zone to be a smoke control area. It is an offence to emit smoke from a chimney of a building if located in a designated smoke control area. It is also an offence to acquire an "unauthorised fuel" for use within a smoke control area unless it is used in an "exempt" appliance.

The Secretary of State for Environment, Food and Rural Affairs has powers to authorise smokeless fuels or exempt appliances for use in smoke control areas in England. In Scotland and Wales this power rests with Ministers in the devolved administrations for those countries. Separate legislation, the Clean Air (Northern Ireland) Order 1981, applies in Northern Ireland. Therefore it is a requirement that fuels burnt or obtained for use in smoke control areas have been "authorised" and that appliances used to burn solid fuel in those areas (other than "authorised" fuels) have been exempted for each area of administration. Further information on the requirements of the Clean Air Act can be found here: <http://www.gov.uk/smoke-control-area-rules>.

The Kirkham has been recommended as suitable for use in smoke control areas when burning dry wood and the "authorised" smoke free solid fuels. The Kirkham must be fitted with a permanent stop to prevent closure of the secondary air control beyond 3mm open.

The "authorised" solid fuels you are permitted to burn in a smoke control zone include: anthracite (this is naturally occurring smokeless fuel and is the test fuel normally used and recommended), Ecoal 50, Homefire, Homefire ovals, Phurnacite, Taybrite and Multiheat.

2.4.10 Refuelling Onto a Low Fire Bed

If the fire bed is not sufficient to light a new fuel charge, excessive smoke emission can occur. Refuelling must be carried out onto a bed of glowing embers and ash such that the new fuel ignites in a reasonable period. If there are too few embers in the fire bed, add kindling to prevent excessive smoke.

2.4.11 Fuel overloading

The maximum amount of fuel specified in this manual should not be exceeded, overloading can cause excess smoke and damage to the appliance and chimney system.

2.4.12 Operation with door left open

Operation with the door open can cause excess smoke and will reduce the efficiency of the stove by up to 50% (as well as presenting an obvious fire risk) and significantly reduce the air quality which may result in a risk to your health. The stove must not be operated with the stove door left open except as directed in the instructions.

2.4.13 Dampers left open

Operation with the air controls or stove dampers open can cause excess smoke. The stove must not be operated with air controls, stove dampers or door left open except as directed in the instructions.

3.0 MAINTENANCE

3.1 GENERAL MAINTENANCE

Only ever carry out maintenance when the stove is cold.

The following elements of maintenance may be carried out by the end user. Any repairs, for example internal chamber bricks, baffle plate, collar or connecting flue pipe, but not limited to must be carried out by a suitably qualified competent installer.

3.1.1 Baffle Plate Removal and Replacement

Note the position before removal. To remove baffle plate, firmly push the baffle plate upwards with one hand then use another hand to manoeuvre the side chamber bricks out of the stove. With the side chamber bricks removed, the baffle plate can be lowered and withdrawn from the open doorway of the stove.

To replace, place the baffle plate inside the stove in the correct alignment. With one hand, locate the back edge of the baffle plate onto the top of the rear chamber brick and push the front edge of the baffle plate towards the top of the stove. With another hand, place the side chamber bricks into the stove and firmly into position and release the baffle plate so that the front lip sits between both side bricks.

Care must be taken not to damage the bricks when removing or replacing during this operation.

3.1.2 Sweeping the Chimney

The sweeping and cleaning should only be carried out by a competent person. The chimney system will need to be cleaned/swept annually but not limited to depending on use. Your chimney should also be cleaned/swept before starting to use your stove for

the winter if not been in use for some time, as birds may have nested in the chimney or the masonry could have fallen away and caused a blockage.

The chimney can be swept through your stove with the baffle plate removed. It is advisable to remove the bricks too in order to avoid accidental damage. When complete all necessary checks should be carried out to ensure the integrity of the chimney system throughout and the stove safe performance.

3.1.3 Grate Removal and Replacement

Remove the ash pan, side bricks, baffle and rear brick before finally removing the grate. Replacement is in the reverse order. Replacing the grate frequently would suggest that the ash is not removed regularly and thus is allowed to build up under the grate and touch the bars. This will also reduce the air flow during the operation of the stove.

3.1.4 Stove Body

The stove is finished with a heat-resistant paint and this can be cleaned with a soft brush. Do not clean whilst the stove is hot – wait until it has cooled down.

The finish can be renovated with high temperature stove paint as supplied by the manufacturer. Aerosols must never be used when the stove is hot or in operation, only use when the stove is cold.

3.1.5 Glass Panels

The glass panel window must only be cleaned when the stove is cold. Highly abrasive substances should be avoided as these can scratch the glass and make subsequent cleaning more difficult. Do not burn wet logs, large logs that do not fit in the combustion chamber, overload with multiple logs as this can also damage the glass and in some instances cause the glass to fracture. Do not slam the door as this can also cause a crack to occur.

Should a glass window require to be replaced, then remove the four screws and clips on the retaining bar which retains the glass in place, carefully remove the broken glass and replace the window with the correct stove glass from your supplier. When replacing the glass we recommend also replacing the rope seal in all instances. The retaining steel frame can then be put back in place and the clips and screws then secured to retain it in position.

3.2 SEASONAL MAINTENANCE

If your stove is left unused for any length of time, in particular over the summer months, then it is recommended that it is cleaned out thoroughly prior to any use in the future. When left for prolonged periods it is recommended that the stove is allowed to have a continued air flow throughout. In doing so this action will reduce the risk of any rust forming. This can be achieved by leaving the primary and secondary air controls in the openable position and the internal components should be lightly oiled with a suitable lubricant. In some instances the door can also be left partially open to allow for better air circulation. Periodic monitoring of the inside components will identify condensation or water ingress. If these problems occur, then your stove needs to be dried and the cause of the problem identified initially and then rectified immediately.

4.0 SAFETY NOTES AND TROUBLESHOOTING

4.1 CO ALARMS

Percy Doughty requires that a new carbon monoxide alarm must be fitted in the same room as the stove when installed. This includes a new or replacement appliance also. Further guidance on the installation of the carbon monoxide alarm is available in BS EN 50292:2002 and from the alarm manufacturer's instructions. See page 8 of this manual for guidance on the positioning of a CO alarm. Provision of an alarm must not be considered a substitute for either installing the stove correctly or ensuring regular servicing and maintenance of the stove and chimney system. It is advisable that the CO alarm is tested at least once a month. Guidance on how to test should be sought from your installer in accordance with the manufacturer's instructions.

Stoves can be dangerous. Always use a fire guard to BS 8423:2002 in the presence of children, the elderly or the infirm. Inform all persons of the dangers of high temperatures during operation of stove including the connecting flue pipe.

Do not use this stove as an overnight burner, when finished for the evening, leave the air controls open to allow the remainder of the fuel to burn out.

Use the glove provided to open the door and never empty the ash pan when it is hot.

4.2 DO NOT OVER-FIRE

It is possible to fire the stove beyond its intended nominal design capacity, this could damage the stove. Signs of over-firing could include components showing significant

signs of distress, discoloration, cracks appearing on the stove body or other. If using excessive fuel in short periods of operation and in extreme circumstances parts of the stove and connecting flue pipe would be glowing red. In all instances the stove must not be used until it has been checked for safety. Never leave the stove unattended for long periods without adjusting the controls to a safe setting – only operate the stove within the set parameters when using the air controls and only add the recommended quantity of fuels.

4.3 SMOKE AND PRODUCTS OF COMBUSTION (POC) ENTERING THE ROOM

When installed and operated correctly in accordance with the installation manual, this stove should not emit products of combustion into the room. Occasional products of combustion from de-ashing and refuelling may occur and is normal. Any spillage other than from refuelling or de-ashing must not be tolerated and if apparent the stove must not be used until the chimney system and installation whole has been checked accordingly.

If the spillage of the combustion products persists, then the following immediate action should be taken:

1. Close the door on the stove, opening all doors and windows
2. Move outside into fresh air
3. Wait for smoke to clear before re-entering the room
4. Keep the windows and doors open until the fire has completely extinguished
5. Do not use again until it has been checked by a suitably qualified component engineer

4.4 CHIMNEY FIRE

Identified by loud roaring sounds, dense smoke and sparks exiting chimney. Shut down all air supplies to the stove by closing the air controls and ensure that the stove door is fully closed. In the event of a chimney fire, get out of the house safely, stay out and call the Fire Brigade immediately. Regular chimney maintenance will prevent chimney fires therefore it is best to seek advice from a qualified chimney sweep to arrange for a suitable maintenance schedule.

4.5 POOR HEAT OUTPUT

Poor heat output from your stove could mean several things. The following are typical examples. The fuel used could be incorrect, (too wet or too dry) the flue draught may be excessive and outside the set operational parameters. The stove may be in adequately sized for the room in which its situated. The building fabric may be leaking and further attention needed to prevent the heat loss. In all instances guidance should be sought from a suitably qualified complement engineer.

4.6 ROOM VENTILATION RESTRICTED.

If purpose ventilation is provided for the safe operation of the stove then this must not be blocked, closed or restricted in any way.

4.7 FUEL QUALITY

Only burn dry seasoned timber, soft woods have a lower heat output than hard woods. Solid fuels vary in heat value and sulphur content therefore it is important to check with your coal merchant as to the suitability.

4.8 DIRTY GLASS

Dirty glass is almost always caused by poor fuel quality and the incorrect use of the air controls, always check the moisture content of the wood you are burning with a moisture meter and if in doubt seek further guidance on how to use the stove correctly.

4.9 UN-BURNT FUEL

Insufficient air reaching fuel - adjust the air controls to supply combustion air to burn fuel fully. Check if the ash pan is full, empty if required. Front bar/fret may be blocked, de-ash. Check for jammed clinker or nails in grate when the fire is out and cold.

5.0 STOVE ACCESSORIES

The following is a list of stove accessories your retailer will be able to supply:

- Gallery matching graphite high temperature paint
- Stove Glass Cleaner
- Spare Rope
- Rope Seal Adhesive
- CO Detector
- Gallery Stove Fan
- Gallery Stove Thermometer
- Wood Moisture Meter
- Spare Glove
- Permanent Ventilators
- Purpose-built Ash Vacuum Cleaner
- Gallery Ash Carrier
- Gallery Fire Screens
- Gallery Companion Sets
- Gallery Log Baskets
- Gallery Soot Box



Brought to you by Percy Doughty & Co
Imperial Point, Express Trading Estate, Stone Hill Road,

Farnworth, Bolton. BL4 9TN

01204 868 550

www.percydoughty.com